



STOREFRONTS

Center Glazed ♦ Series 451

Typical Details SCREW RACE JOINERY

NOTE: NP225 glazing gaskets are used on both sides of glass. Typical

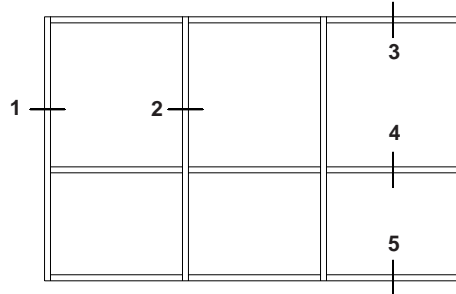

TYPICAL ELEVATION

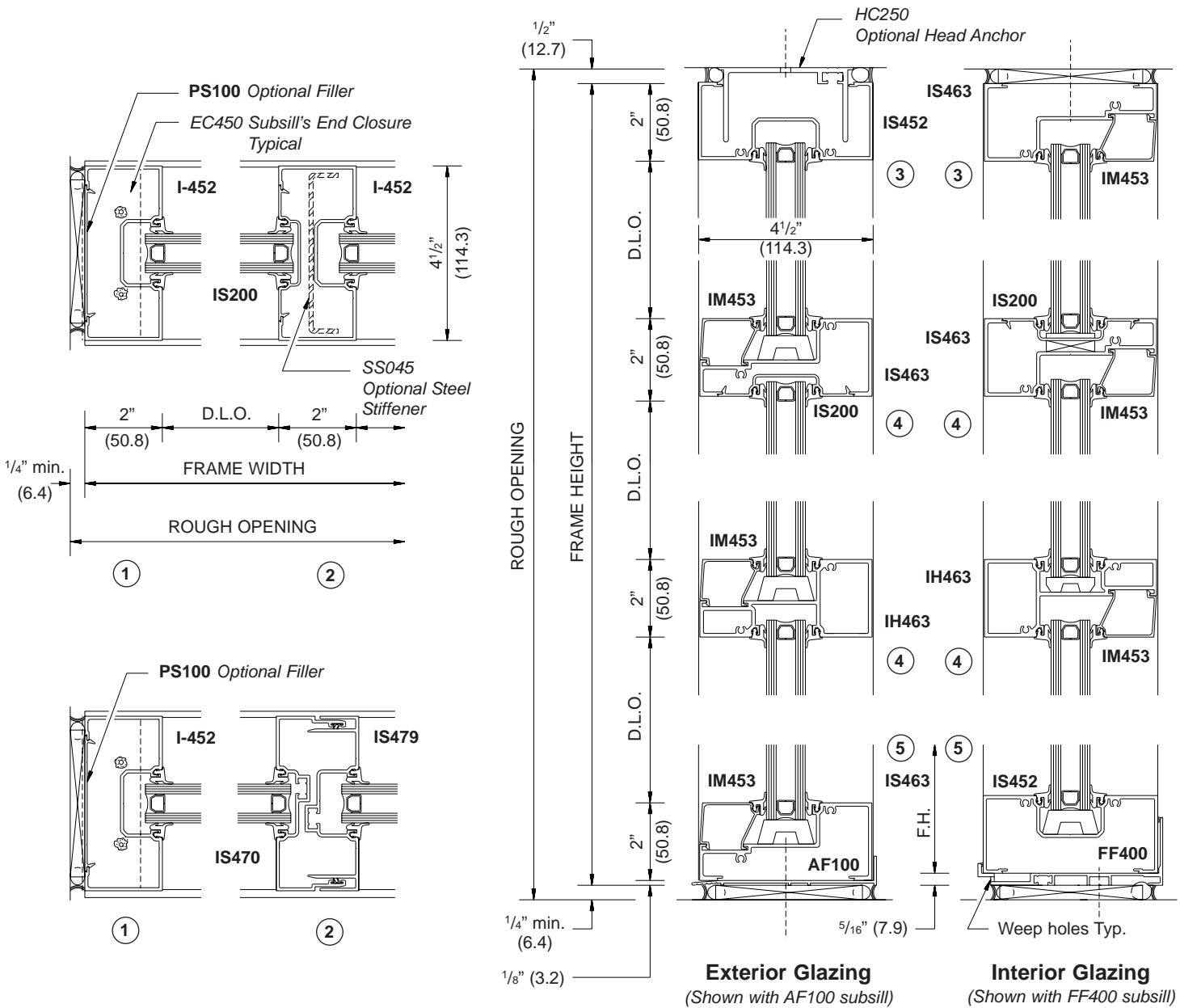

Scale: 3" = 1' - 0"

April 1998

STOREFRONTS



Typical Details ANCHOR CLIP JOINERY

Center Glazed ♦ Series 451

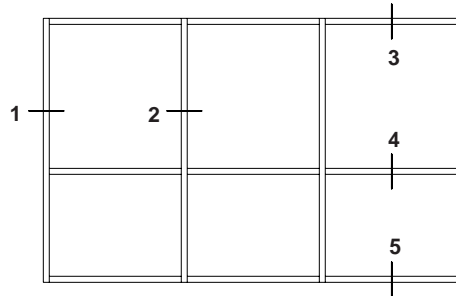

TYPICAL ELEVATION

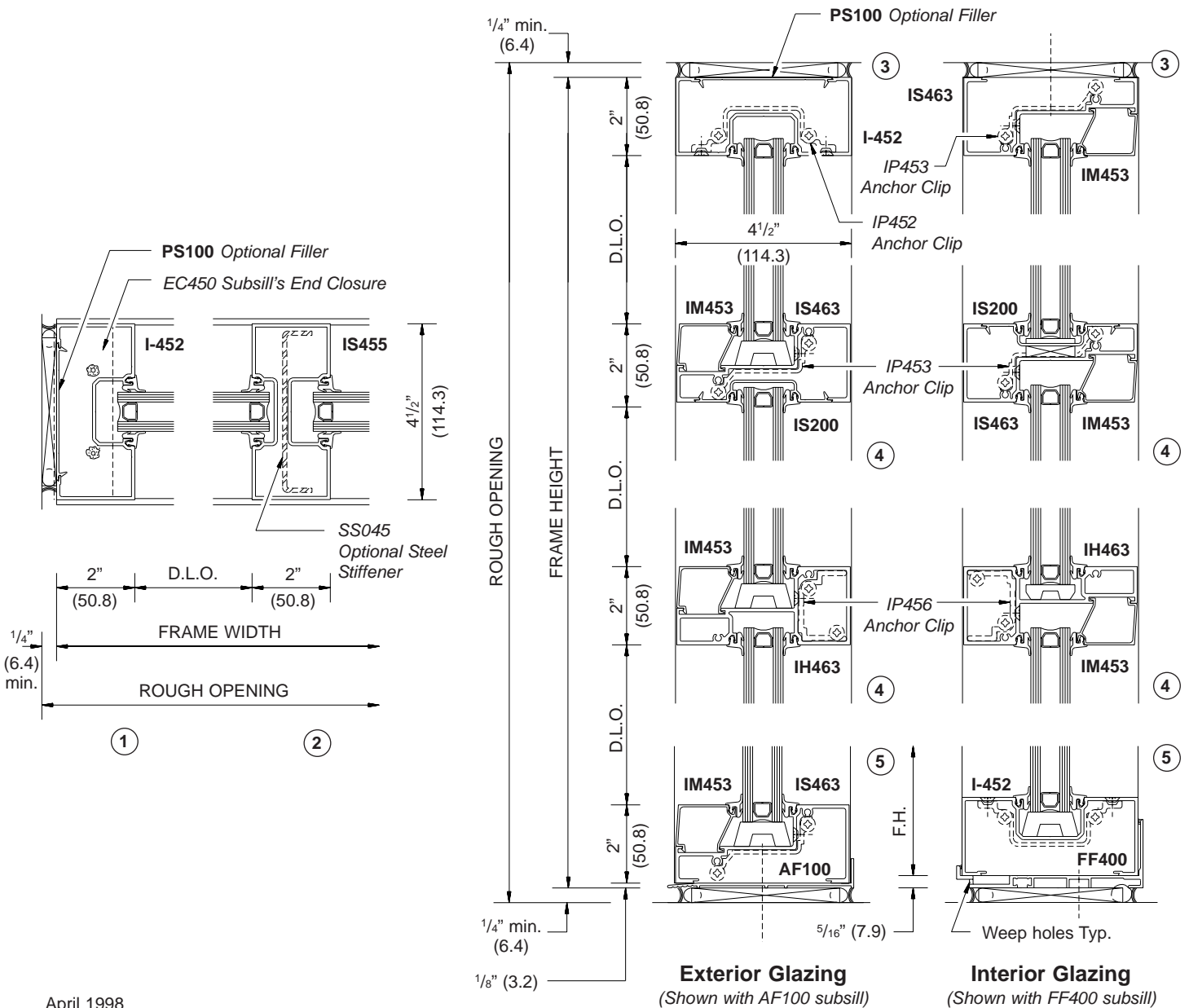



STOREFRONTS

Center Glazed ♦ Series 451-S

Typical Details

STACKING INSTALLATION

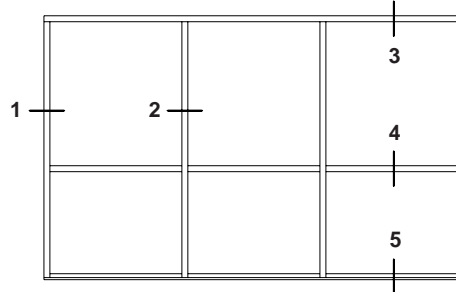

TYPICAL ELEVATION

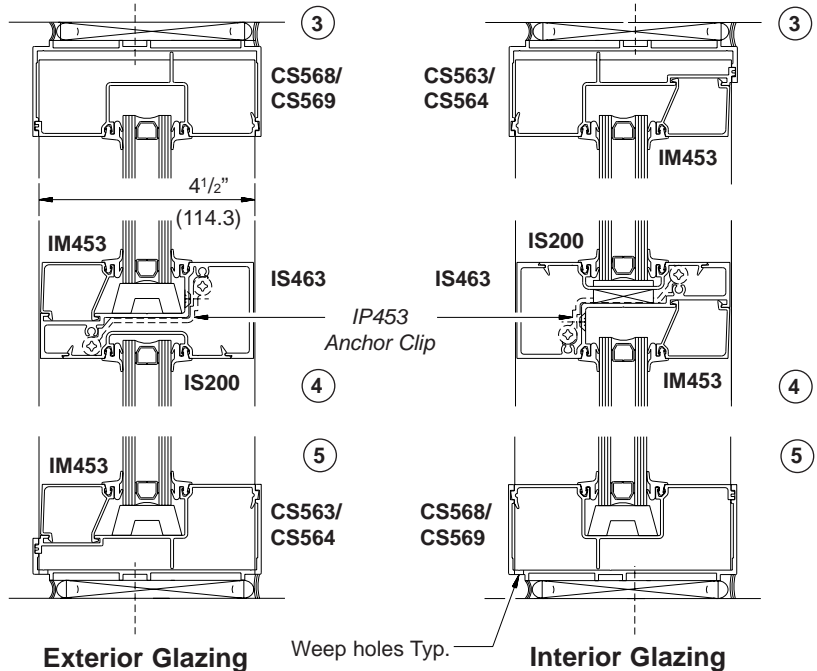
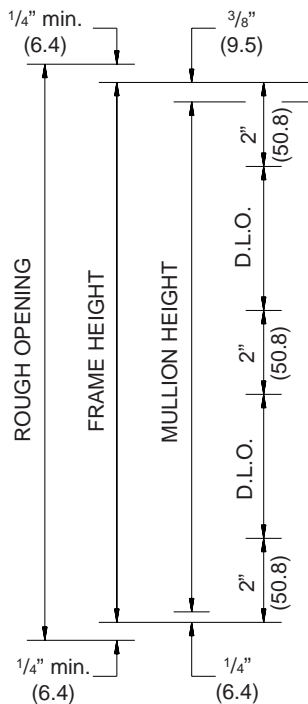
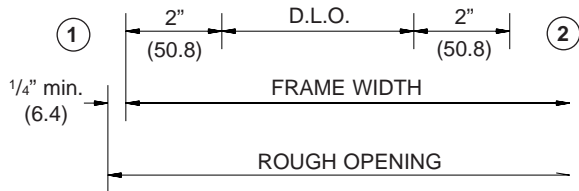
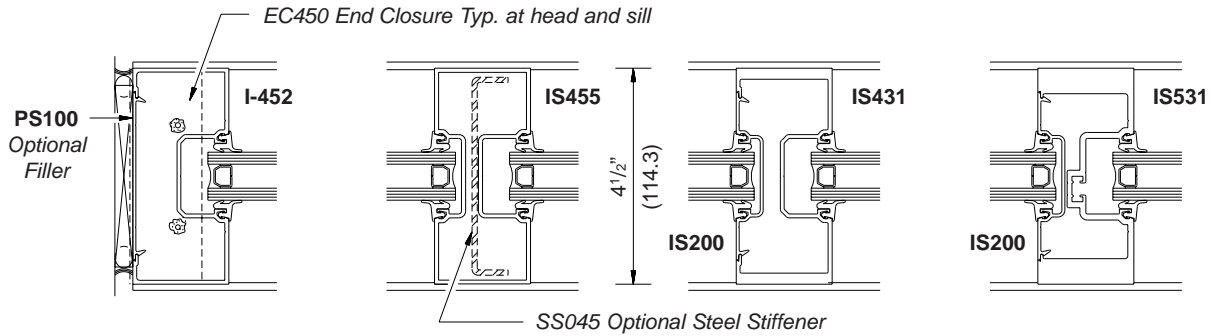

Scale: 3" = 1' - 0"

STOREFRONTS



Typical Details

CORNER CONDITIONS AND POST COVERS

- Center Glazed ♦ Series 451
- ♦ Series 451-S

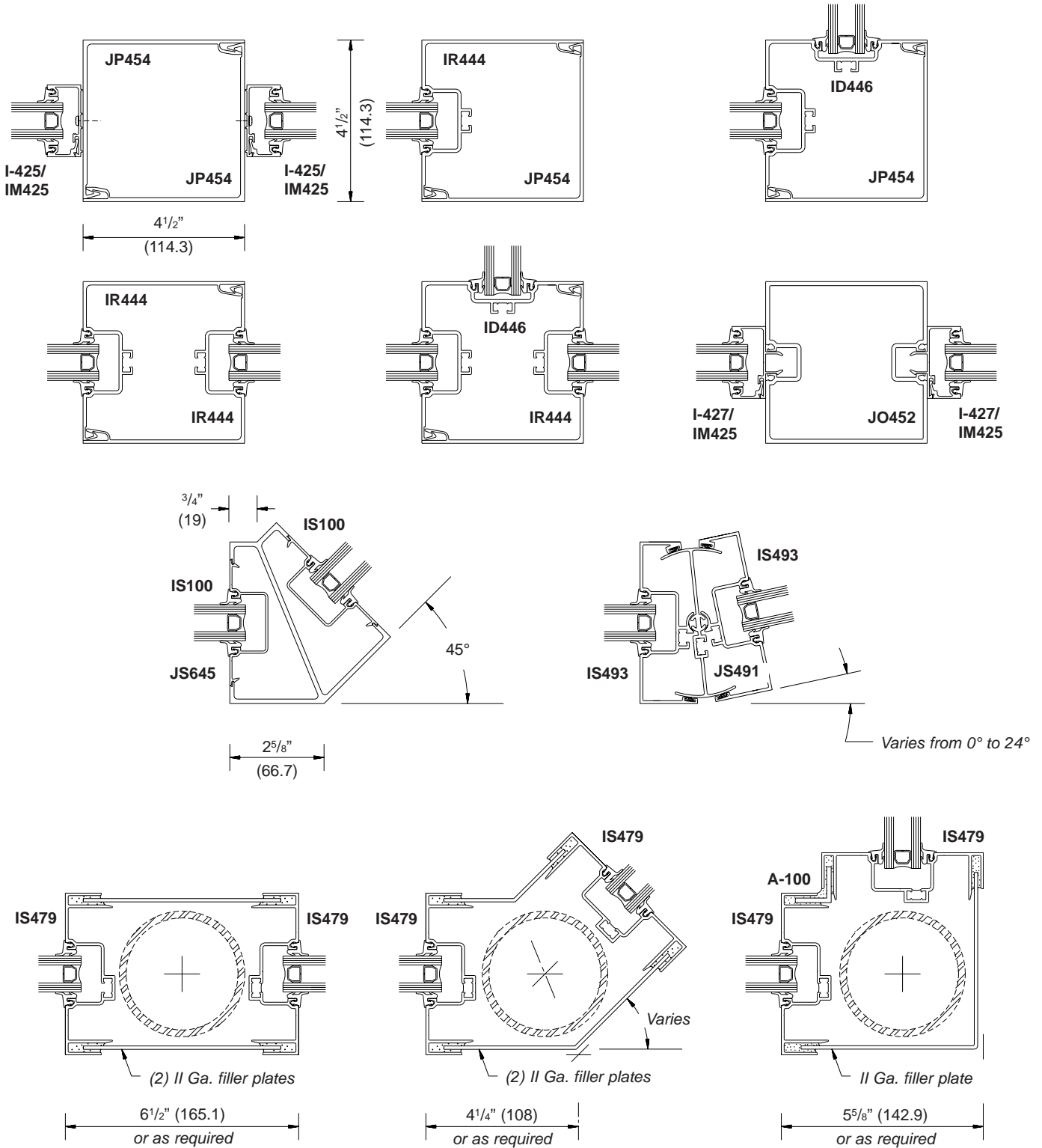



STOREFRONTS

Typical Details

- Center Glazed ♦ Series 451
- ♦ Series 451-S

COMPENSATING CHANNELS

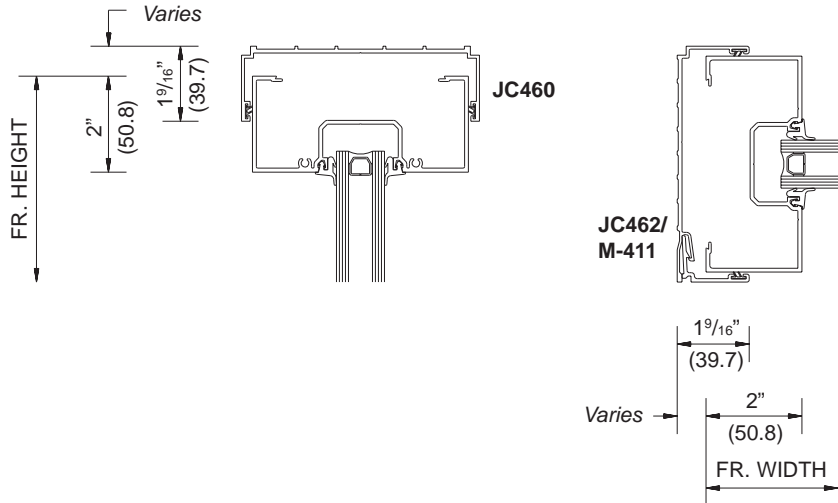

SPECIAL GLASS ADAPTOR

See page 43-B1 for TRANSITION GLAZING

4 1/2" HIGH INTERMEDIATE HORIZONTAL

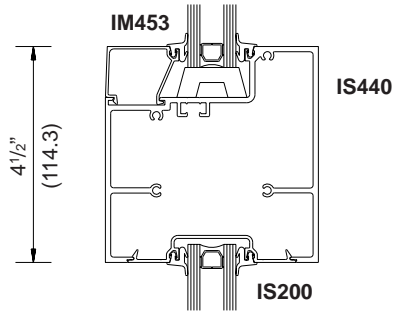
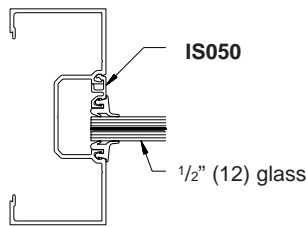

BULKHEADS

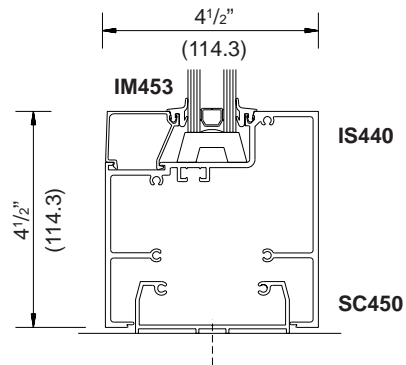
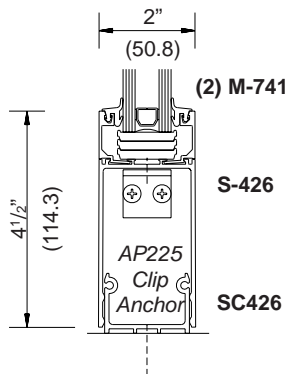

STOREFRONTS



Typical Details DOOR FRAMING

Center Glazed ♦ Series 451
♦ Series 451-S

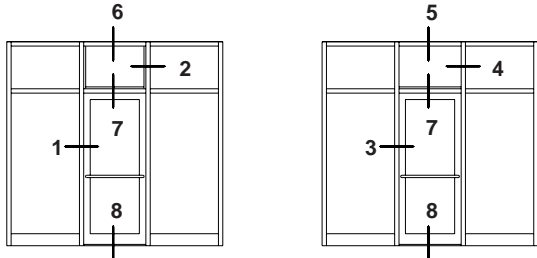

CENTER HUNG DOOR

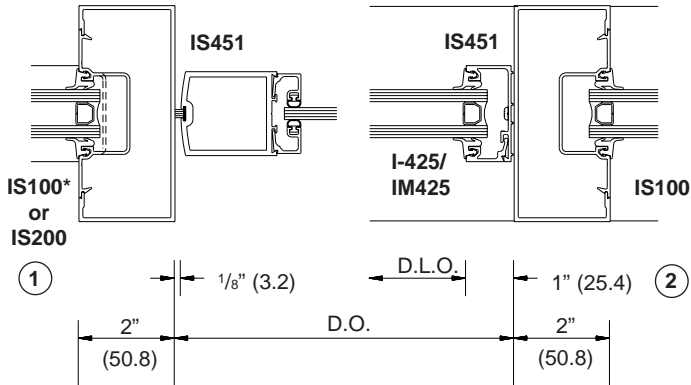

*NOTE: IS100 Insert is required to install glass between doors

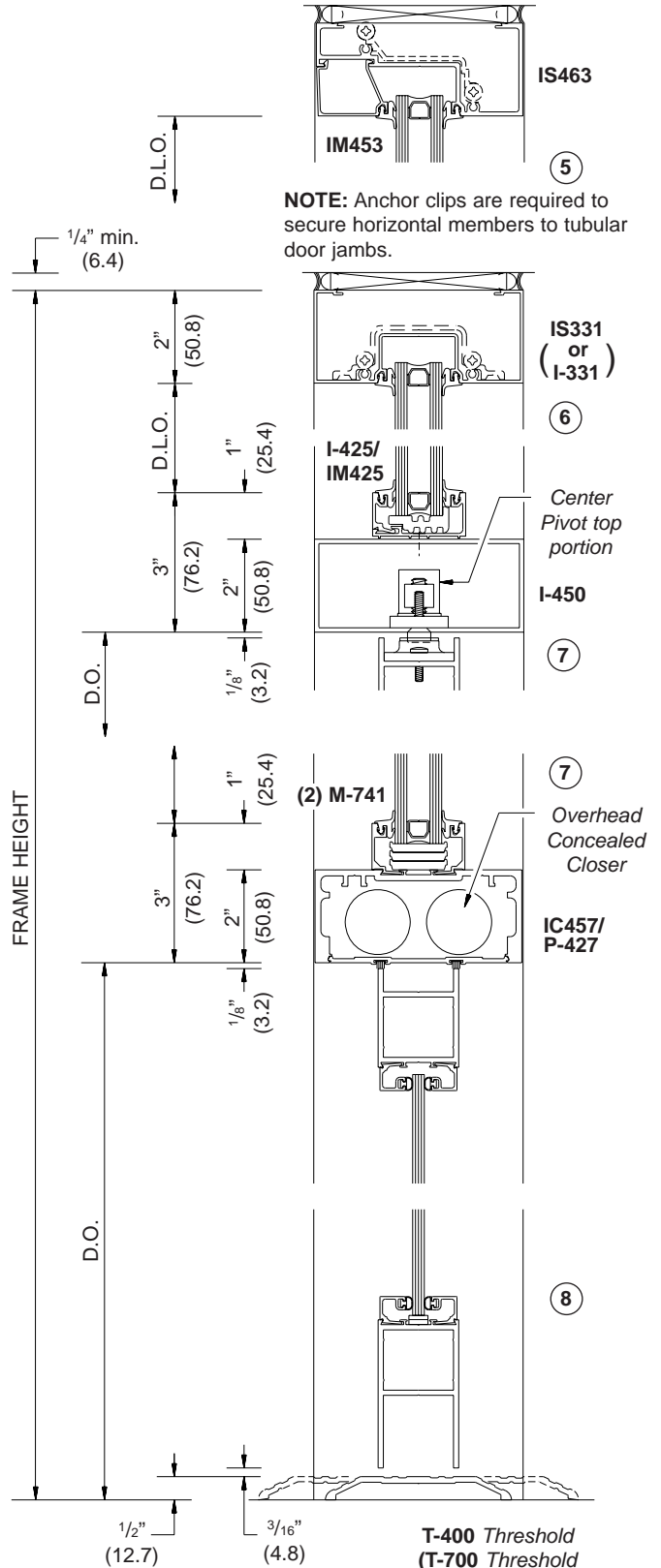
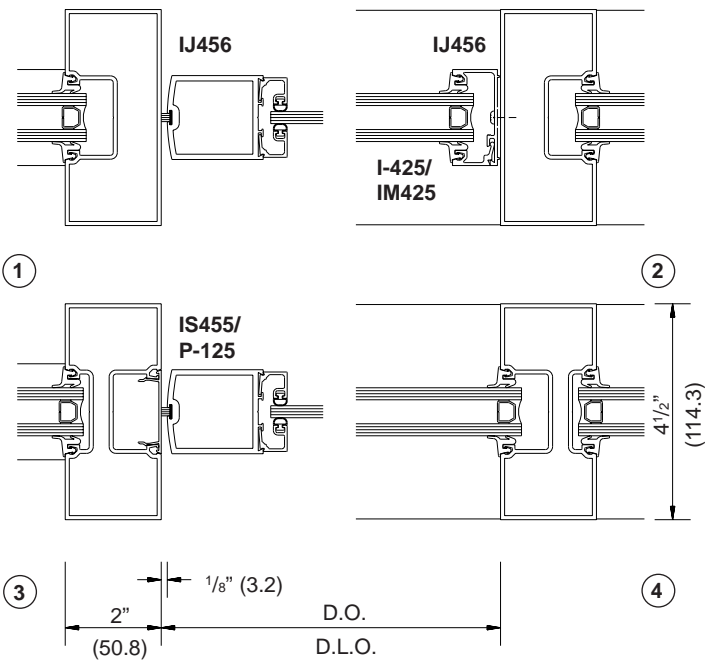

NOTE: Anchor clips are required to secure horizontal members to tubular door jambs.

T-400 Threshold
(T-700 Threshold)
Use with Floor Closers

Scale: 3" = 1' - 0"



STOREFRONTS

Center Glazed ♦ Series 451
 ♦ Series 451-S

Typical Details

DOOR FRAMING

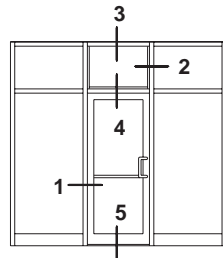

OFFSET HUNG DOORS

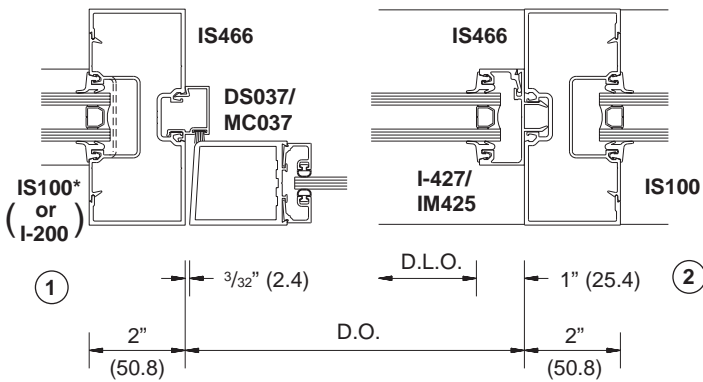

*NOTE: IS100 Insert is required to install glass between doors

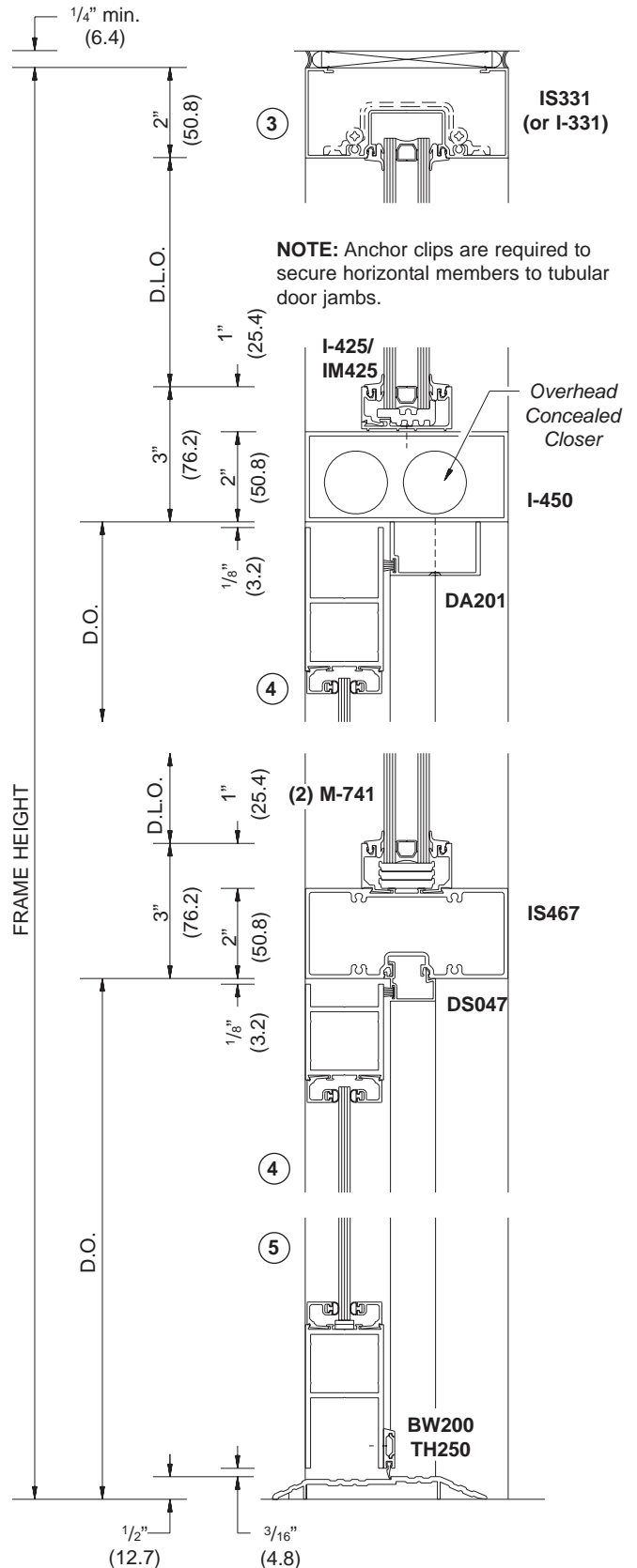
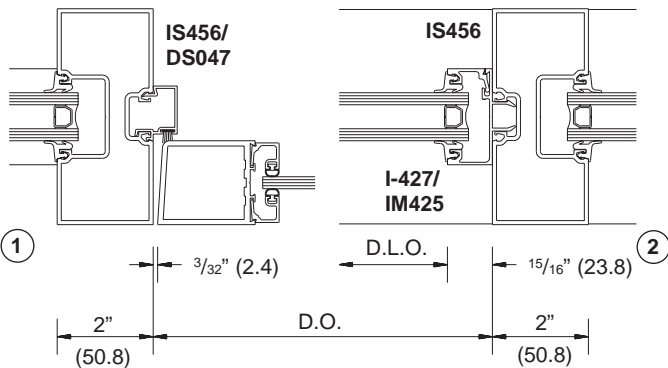

NOTE: Anchor clips are required to secure horizontal members to tubular door jambs.

Overhead Concealed Closer

STOREFRONTS



Typical Details

Center Glazed ♦ Series 451
 ♦ Series 451-S

DOOR FRAMING SPECIAL CONDITIONS

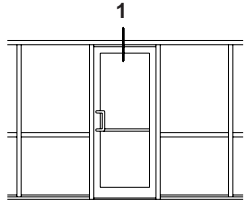

Series 451-S Door Header

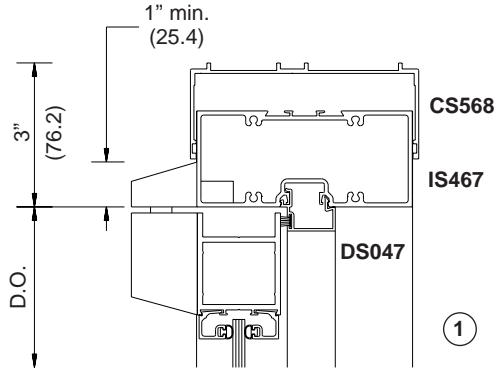

Offset pivoted door

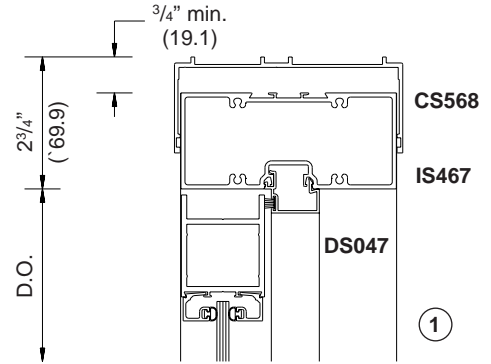

Butt hung door

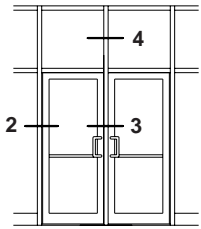

Optional Hinge and Intermediate Door Jamb

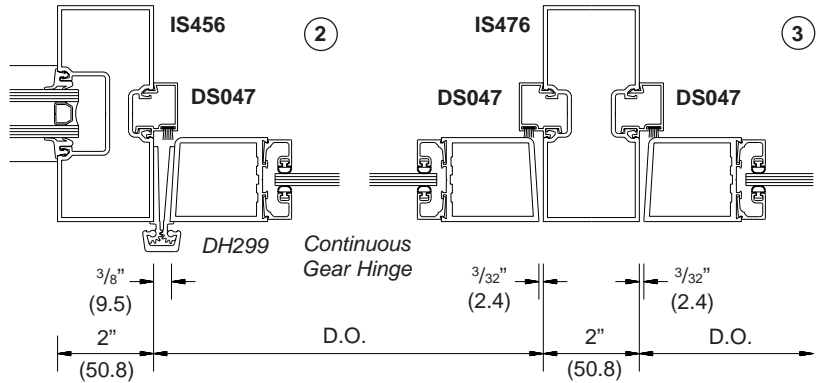

Continuous Gear Hinge

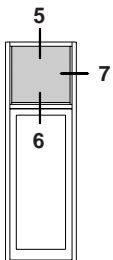
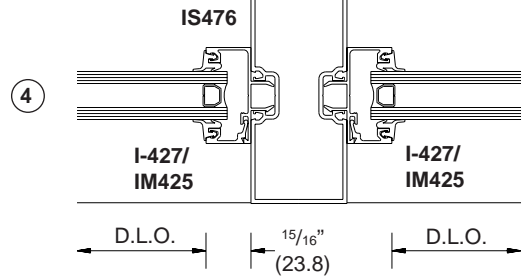

Spandrel Transom

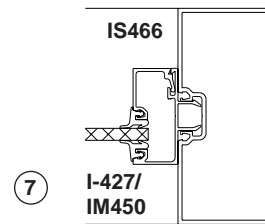
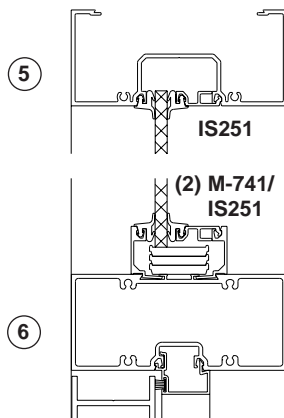



STOREFRONTS

Typical Details TRANSITION GLAZING

- Center Glazed ♦ Series 451
- ♦ Series 451-S

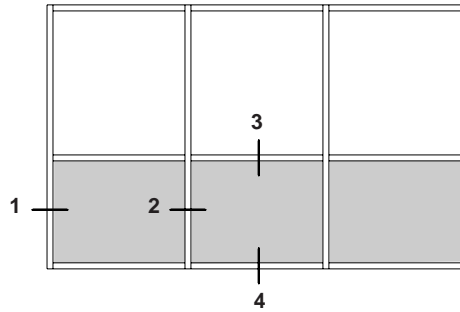

TYPICAL ELEVATION

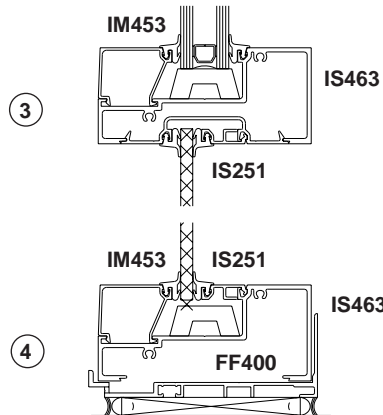
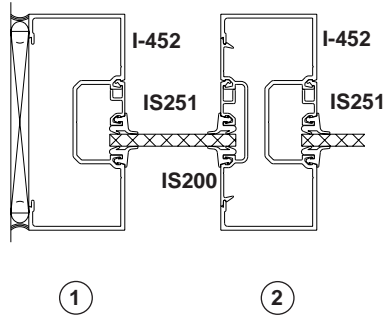

Exterior Glazing

Exterior face of 1/4" (6) glazing aligns with exterior face of 1" (25) glazing

STOREFRONTS



Windload Charts

Center Glazed ♦ Series 451
 ♦ Series 451-S

Mullions designed for $1/175$ deflection ratio and for the following allowable working stresses:

Aluminum alloy 6063-T5: allowable stress for windload 12,929 psi. (89 MPa)
 Steel reinforcing allowable stress for windload 26,666 psi. (183 MPa)

Curves represent the limit values and are based on criteria for simple beam, uniformly loaded, using the distribution of wind forces on the wall with rectangular loading. Glass is not considered as contributing to resistance of deflection.

Limitation of vertical mullions for:
 CURVES A = 15 PSF (718 Pa)
 CURVES B = 20 PSF (957 Pa)
 CURVES C = 25 PSF (1197 Pa)
 CURVES D = 30 PSF (1436 Pa)

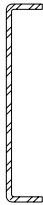

SS045
 Steel Stiffener
 $I = 1.122 (46.70 \times 10^4)$
 $S = .544 (8.92 \times 10^3)$
SS045 fits all verticals except IS431, IS531 and IS470/IS479

Standard wall verticals

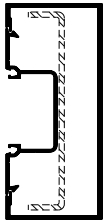

IS451/IS100
 $I = 2.861 (119.08 \times 10^4)$
 $S = 1.271 (20.84 \times 10^3)$
 $I_{AL+STL} = 6.115 (254.52 \times 10^4)$

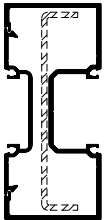

I-452/IS200
 $I = 2.917 (121.41 \times 10^4)$
 $S = 1.296 (21.24 \times 10^3)$
 $I_{AL+STL} = 6.171 (256.85 \times 10^4)$

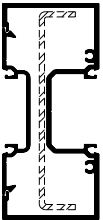

IS452/IS200
 $I = 3.000 (124.87 \times 10^4)$
 $S = 1.333 (21.85 \times 10^3)$
 $I_{AL+STL} = 6.254 (260.30 \times 10^4)$

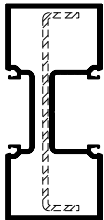

IS455
 $I = 3.005 (125.08 \times 10^4)$
 $S = 1.336 (21.89 \times 10^3)$
 $I_{AL+STL} = 6.259 (260.51 \times 10^4)$

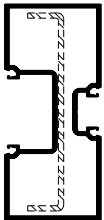

IS456
 $I = 2.951 (122.83 \times 10^4)$
 $S = 1.312 (21.50 \times 10^3)$
 $I_{AL+STL} = 6.205 (258.26 \times 10^4)$

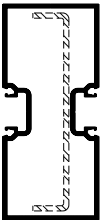

IS476
 $I = 2.848 (118.54 \times 10^4)$
 $S = 1.266 (20.75 \times 10^3)$
 $I_{AL+STL} = 6.102 (253.98 \times 10^4)$

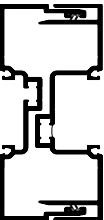

IS479/IS470
 $I = 4.274 (177.90 \times 10^4)$
 $S = 1.877 (30.76 \times 10^3)$

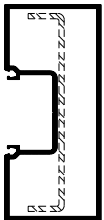

IJ456
 $I = 2.930 (121.96 \times 10^4)$
 $S = 1.302 (21.34 \times 10^3)$
 $I_{AL+STL} = 6.184 (257.39 \times 10^4)$

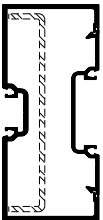

IS466/IS200
 $I = 2.914 (121.29 \times 10^4)$
 $S = 1.295 (21.22 \times 10^3)$
 $I_{AL+STL} = 6.168 (256.72 \times 10^4)$



STOREFRONTS

Windload Charts

- Center Glazed ♦ Series 451
- ♦ Series 451-S

Following charts are based on the section properties of IS452/IS200

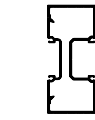
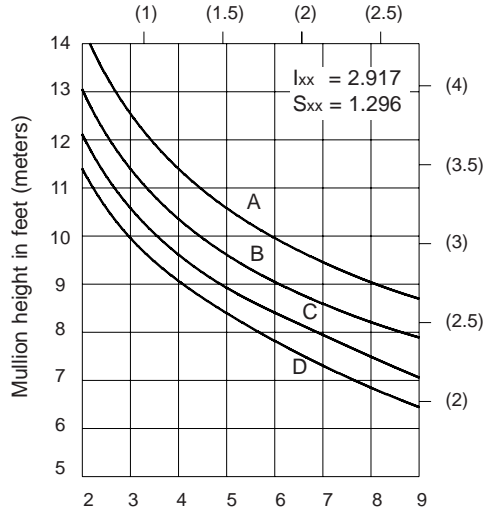

**I-452/IS200
and all stan-
dard verticals**



**I-452/IS200
with SS045**

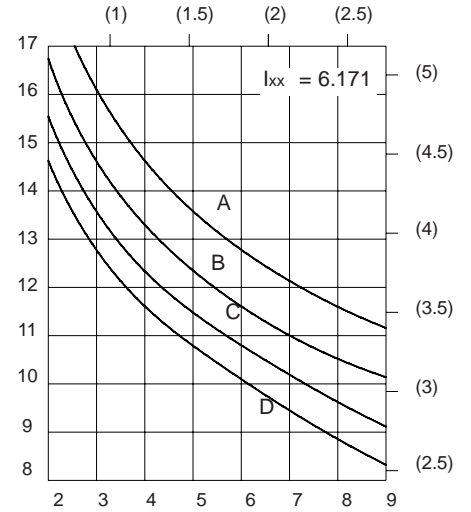

Mullion spacing in feet (meters)

Heavy wall verticals

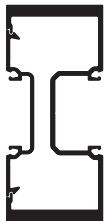

IS431/IS200

$I = 4.990 (207.70 \times 10^4)$
 $S = 2.218 (36.35 \times 10^3)$



IS531/IS200

$I = 9.397 (391.13 \times 10^4)$
 $S = 4.161 (68.19 \times 10^3)$

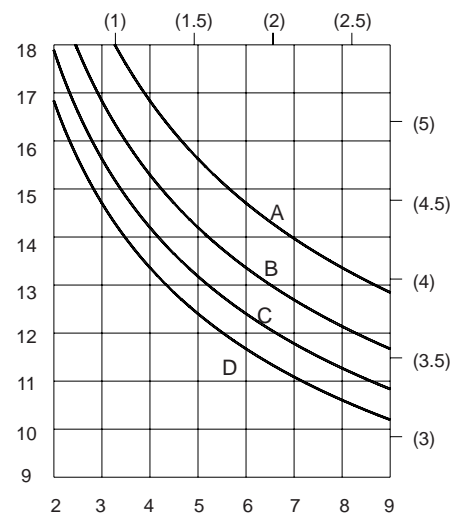
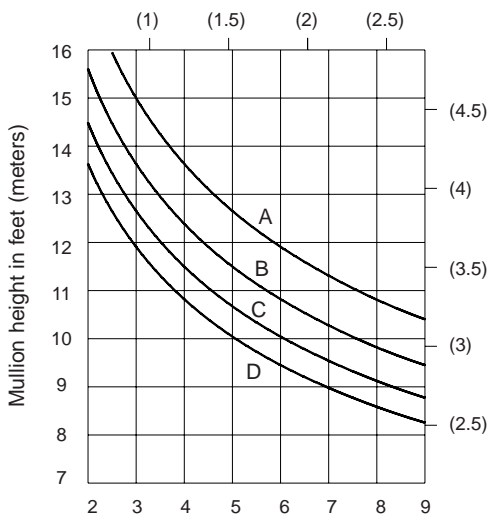

Mullion spacing in feet (meters)

STOREFRONTS



Deadload Charts

Center Glazed ♦ Series 451
 ♦ Series 451-S

INTERMEDIATE HORIZONTALS

Deadload charts are based on 1/8" (3.2) maximum allowable deflection at the center point of the horizontal member and on a glass weight of 6.5 P.S.F. (31.74 Kg/m²)

Glass shall rest on two setting blocks located at:

CURVES A = 1/4 points

CURVES B = 1/8 points or 8" (203.2) from corners, whichever is larger



IS463/IS200

$I_{yy} = .359 (14.94 \times 10^4)$

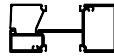

IH463

$I_{yy} = .522 (21.73 \times 10^4)$

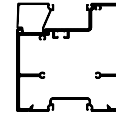

IS440/IS200

$I_{yy} = 3.416 (142.81 \times 10^4)$

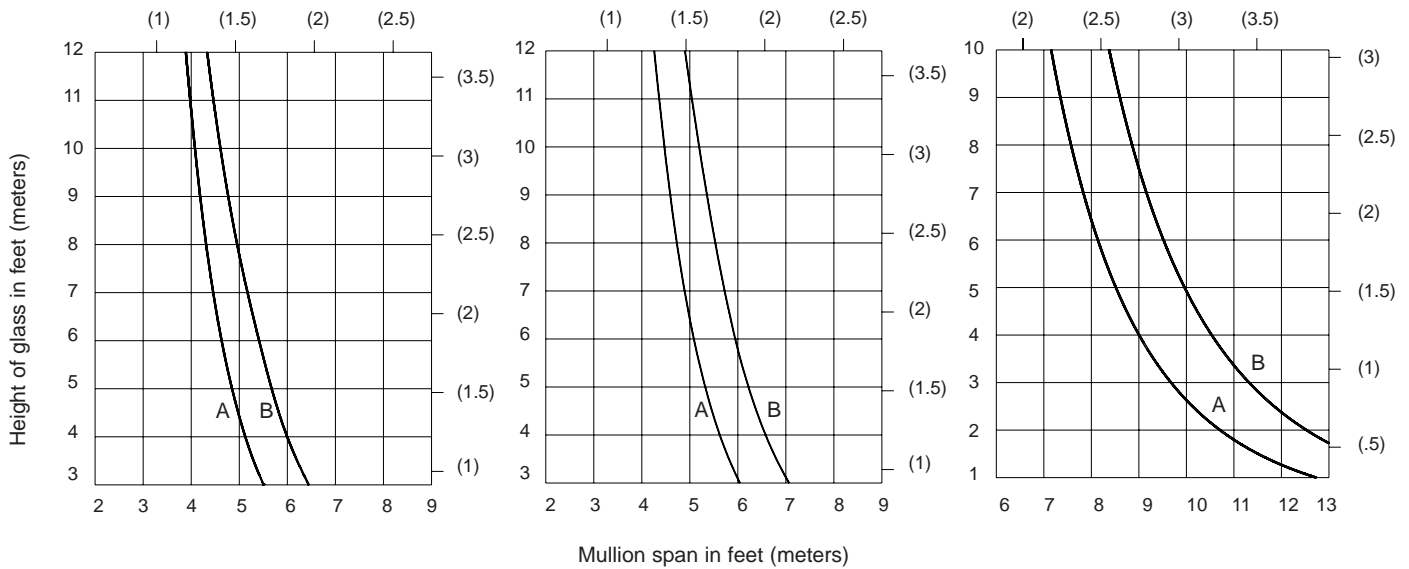

DOOR HEADERS

Deadload charts for door headers are based on 1/16" (1.6) maximum allowable deflection at the center point of the header and on a glass weight of 6.5 P.S.F. (31.74 Kg/m²)

Glass shall rest on two setting blocks located at:

CURVES A = 1/4 points

CURVES B = 1/8 points or 8" (203.2) from corners, whichever is larger



IS467

$I_{yy} = .899 (37.42 \times 10^4)$

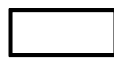

I-450

$I_{yy} = .862 (35.88 \times 10^4)$

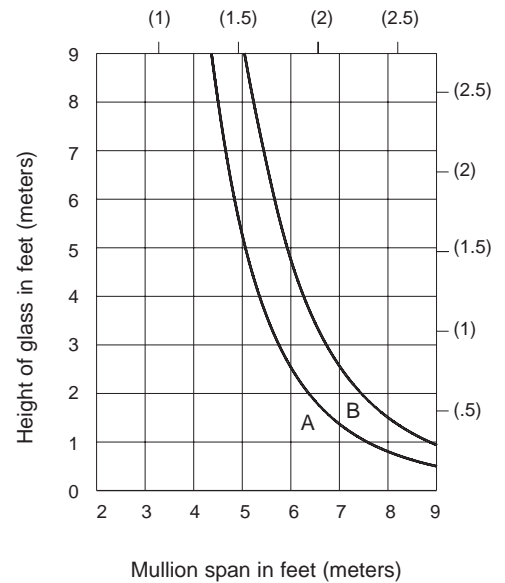



STOREFRONTS

Center Glazed ♦ Series IT451

Typical Details SCREW RACE JOINERY

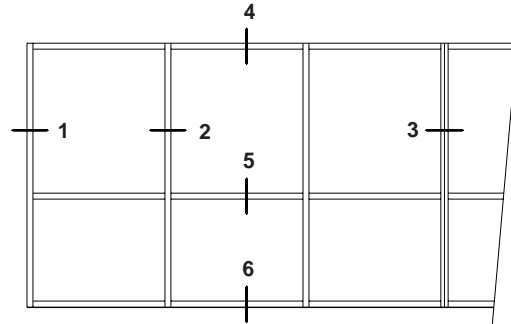

NOTE: NP225 glazing gaskets are used on both sides of glass.
Typical

TYPICAL ELEVATION

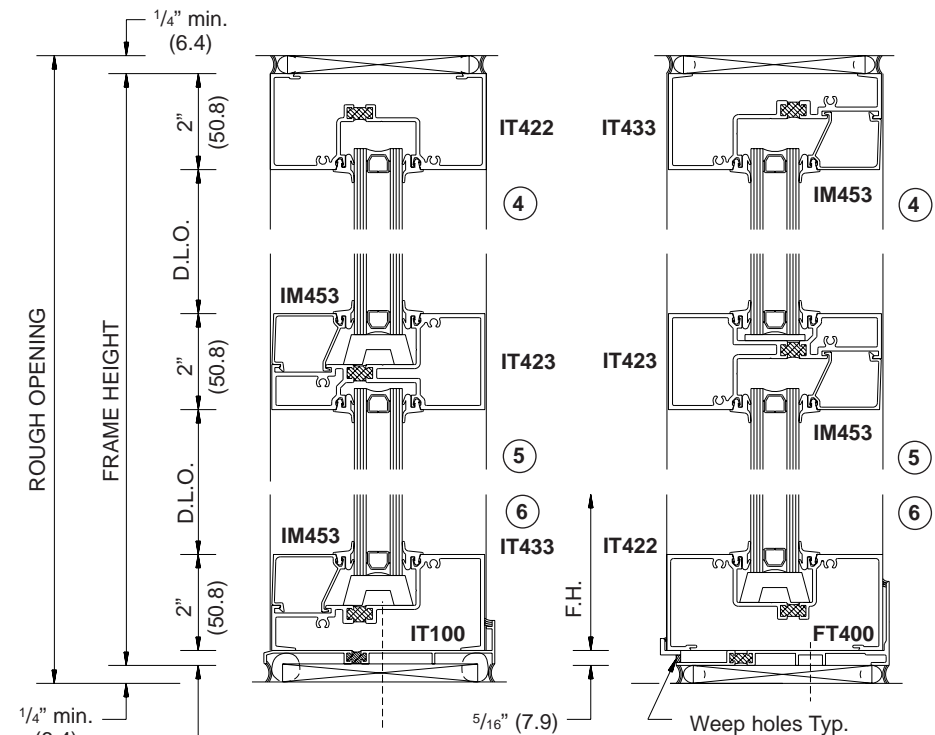
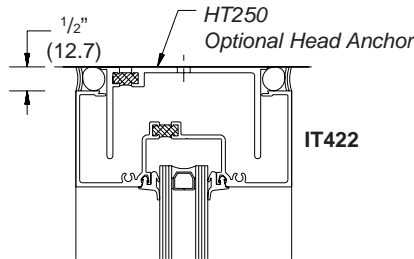
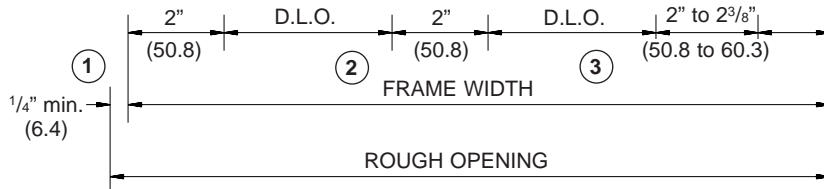
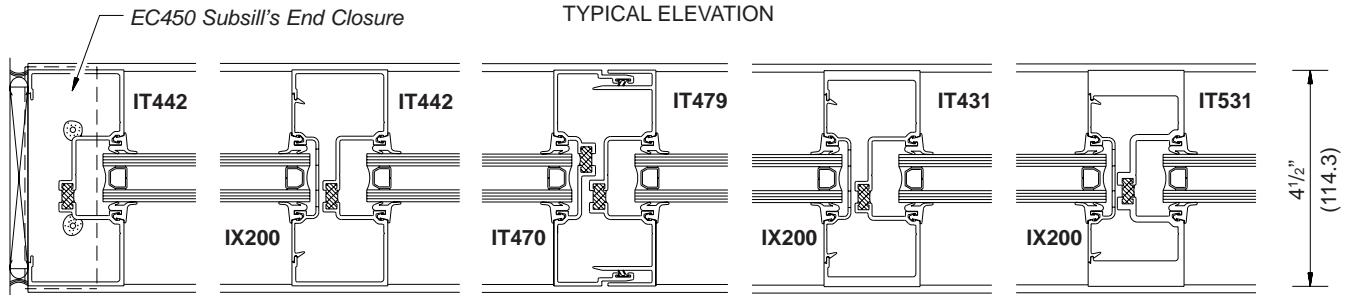

Exterior Glazing
(Shown with IT100 subsill)

Interior Glazing
(Shown with FT400 subsill)

Scale: 3" = 1' - 0"

STOREFRONTS



Typical Details

Center Glazed ♦ Series IT451

ANCHOR CLIP JOINERY

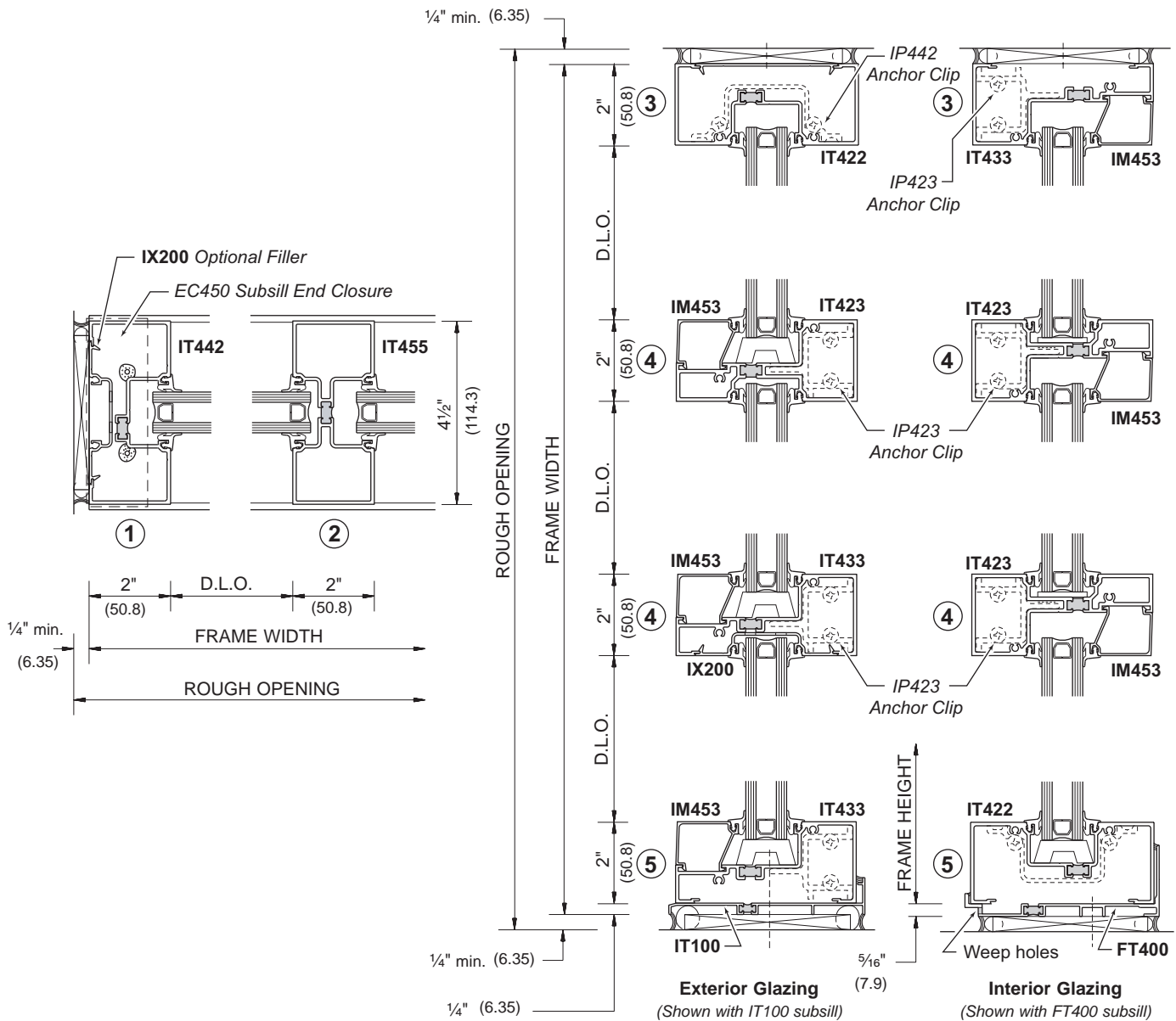
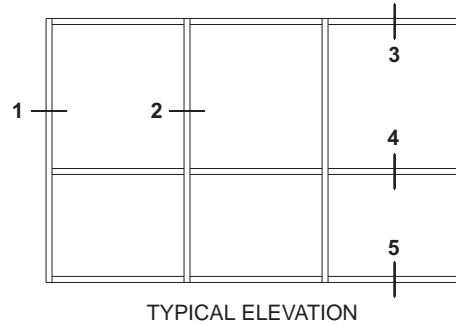



STOREFRONTS

Typical Details

Center Glazed ♦ Series IT451-S

1" (25.4) GLAZING

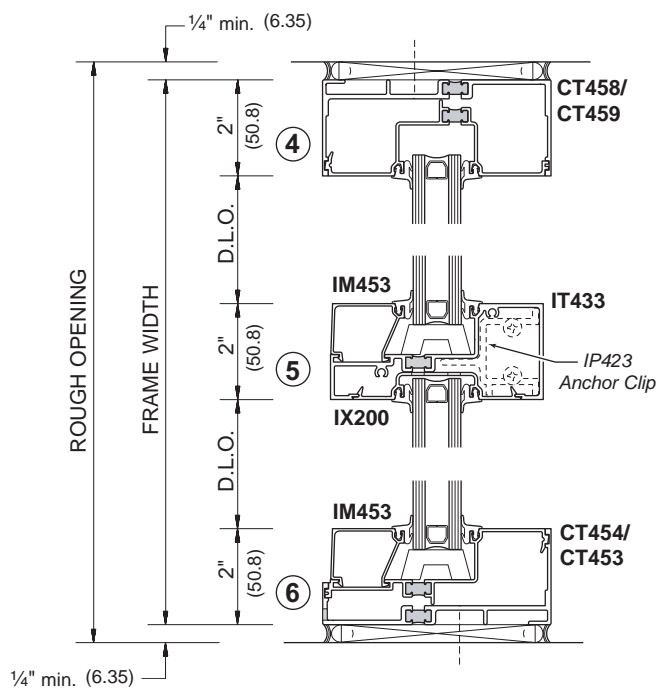
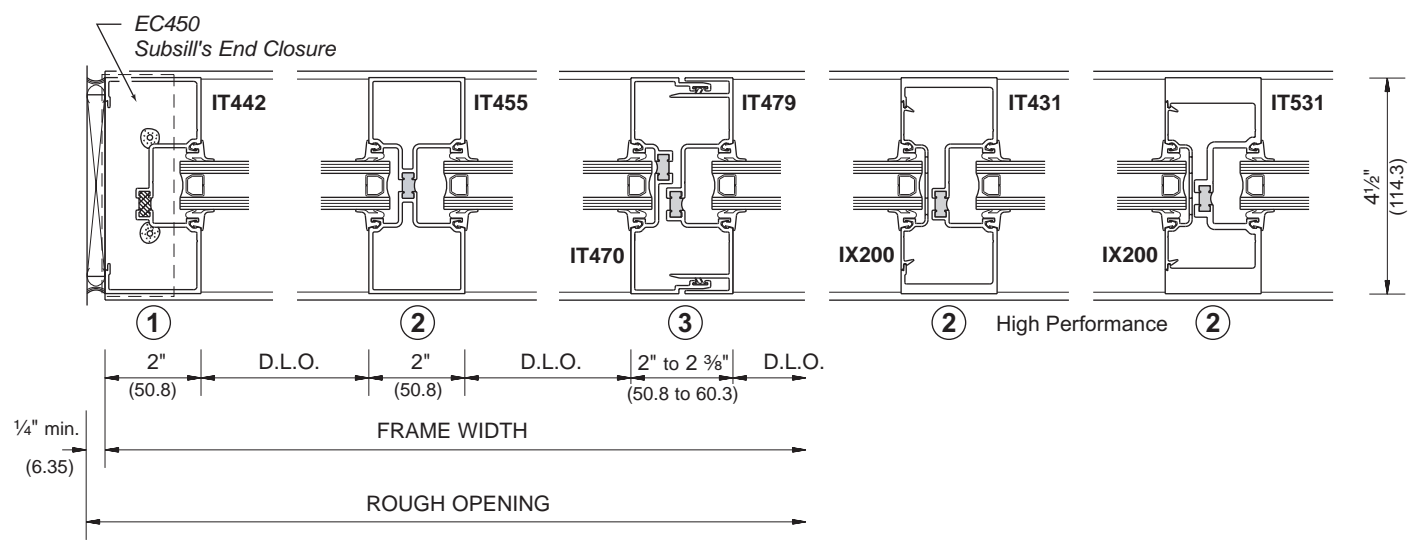
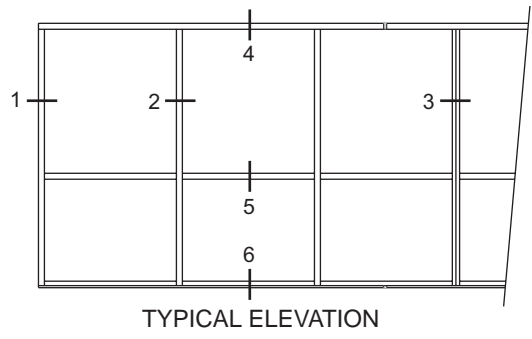

STOREFRONTS



Center Glazed ♦ Series IT451

Typical Details

CORNER CONDITIONS AND POST COVERS

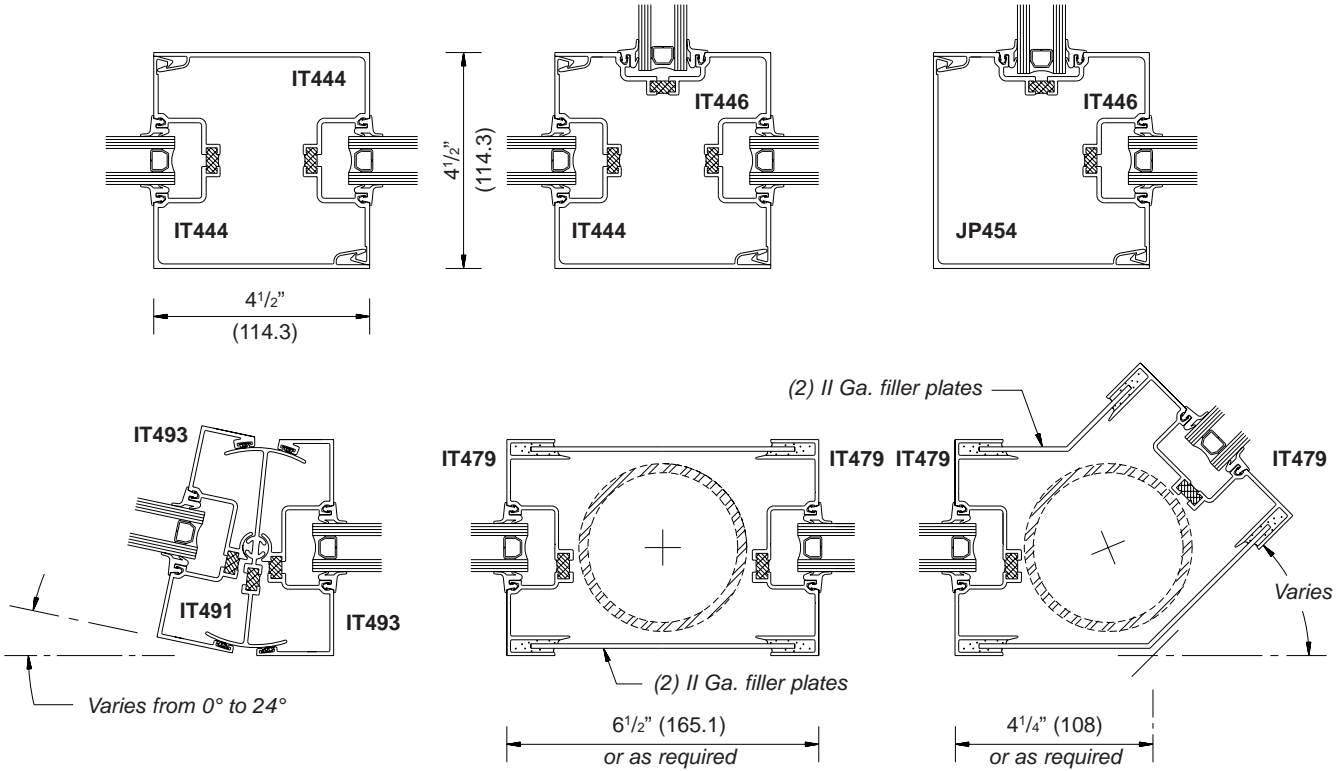

COMPENSATING CHANNEL

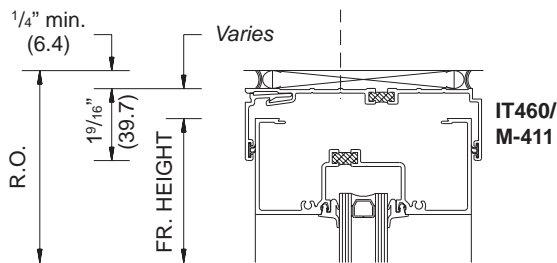

4 1/2" HIGH INTERMEDIATE HORIZONTAL

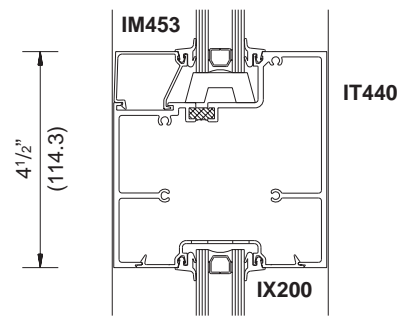

BULKHEAD

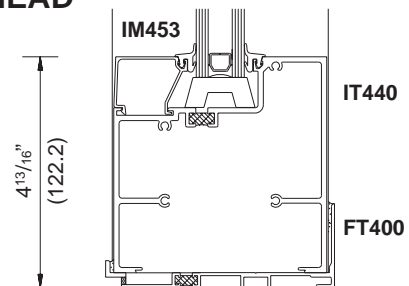



STOREFRONTS

Center Glazed ♦ Series IT451

Typical Details DOOR FRAMING

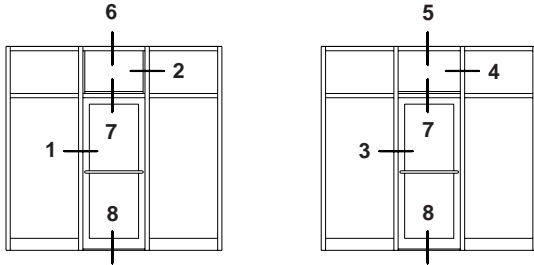

CENTER HUNG DOOR

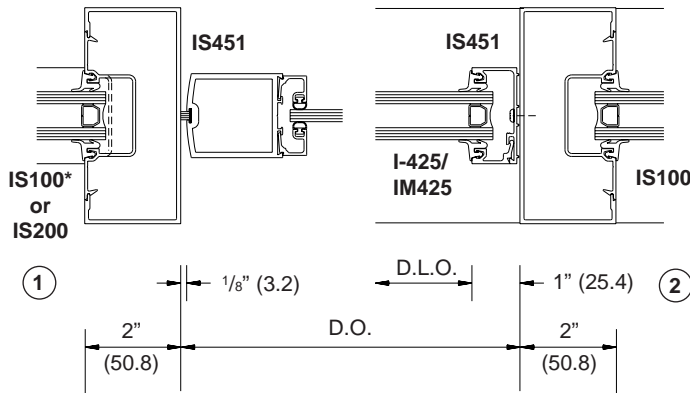

*NOTE: IS100 Insert is required to install glass between doors

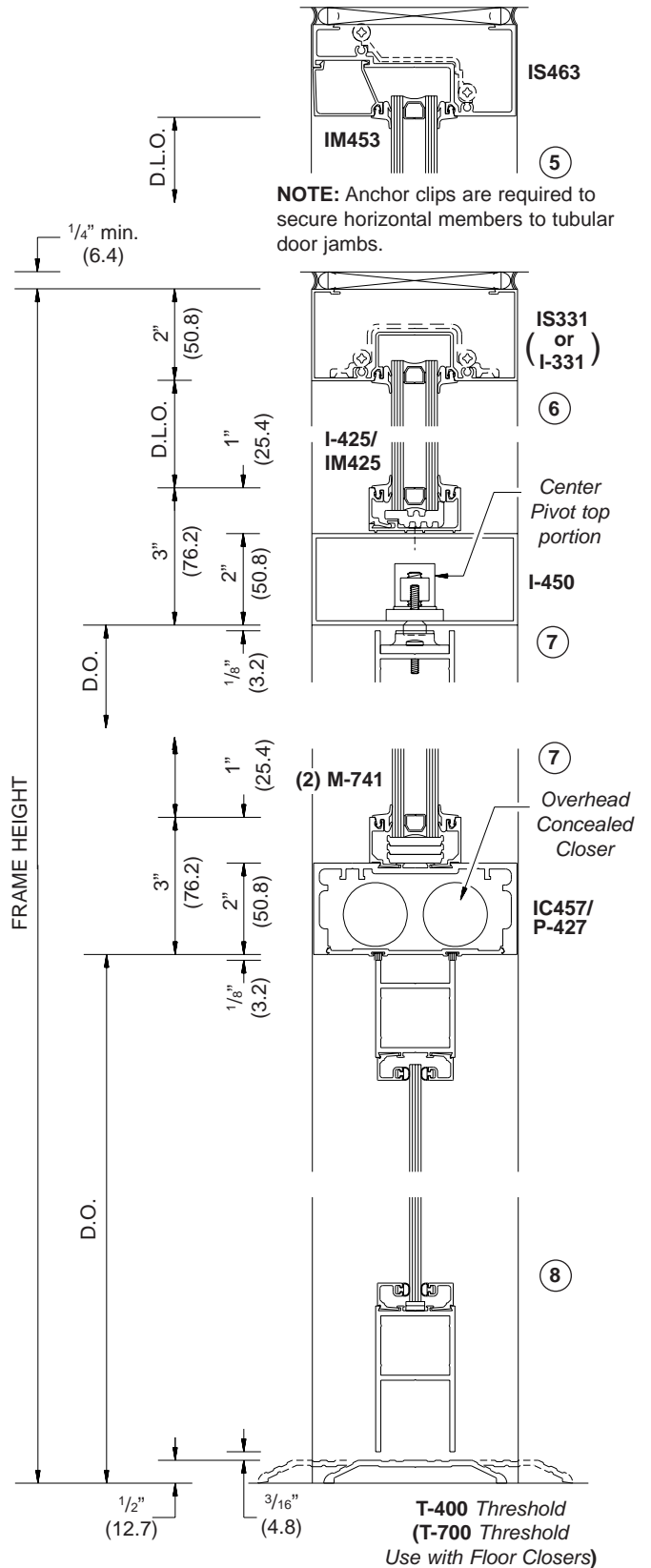
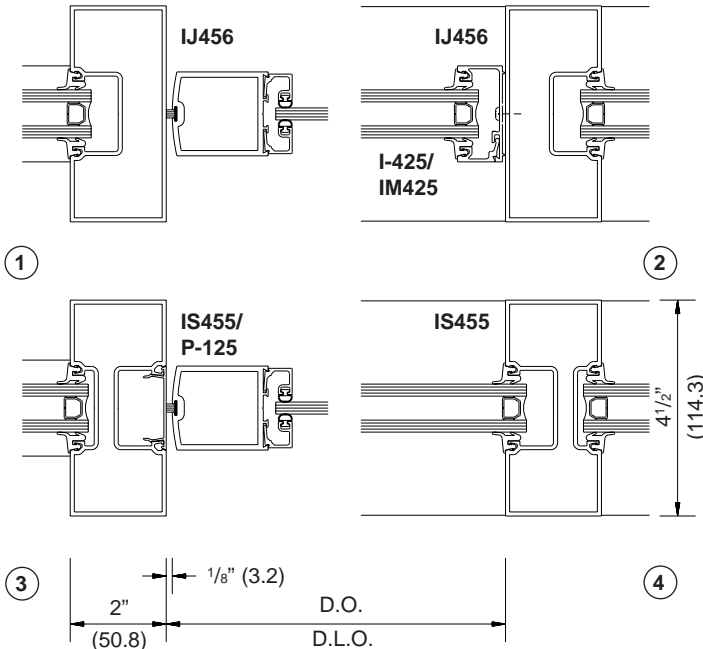

Scale: 3" = 1' - 0"

STOREFRONTS



Typical Details

Center Glazed ♦ Series IT451

DOOR FRAMING

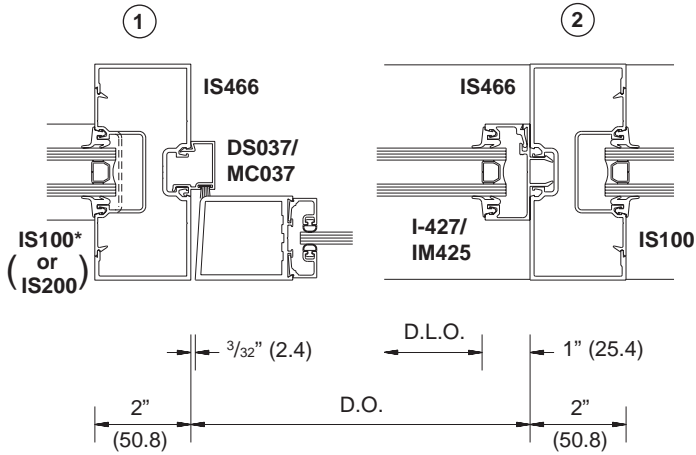
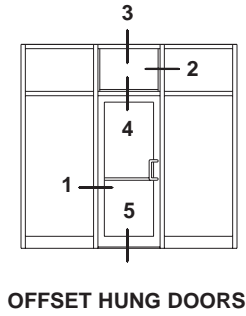

***NOTE:** IS100 Insert is required to install glass between doors

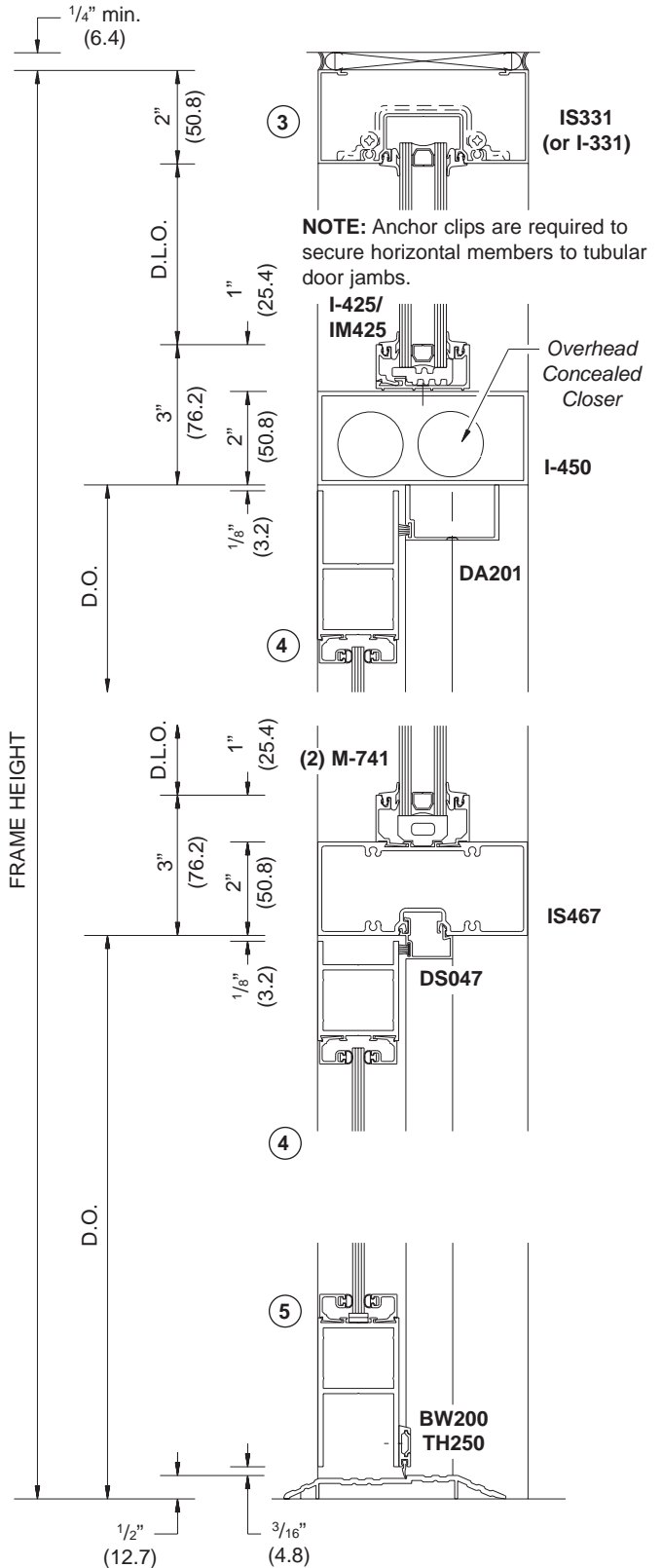
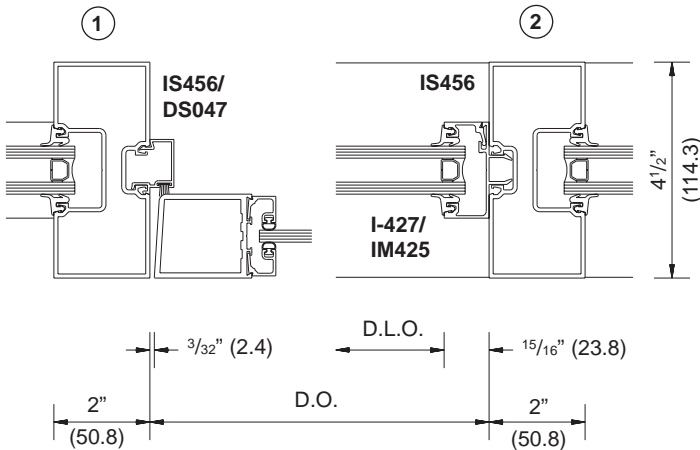



STOREFRONTS

Center Glazed ♦ Series IT451

Typical Details TRANSITION GLAZING

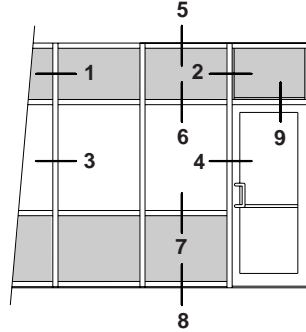

TYPICAL ELEVATION

NOTE: Anchor clips are required to secure horizontal members to tubular door jambs

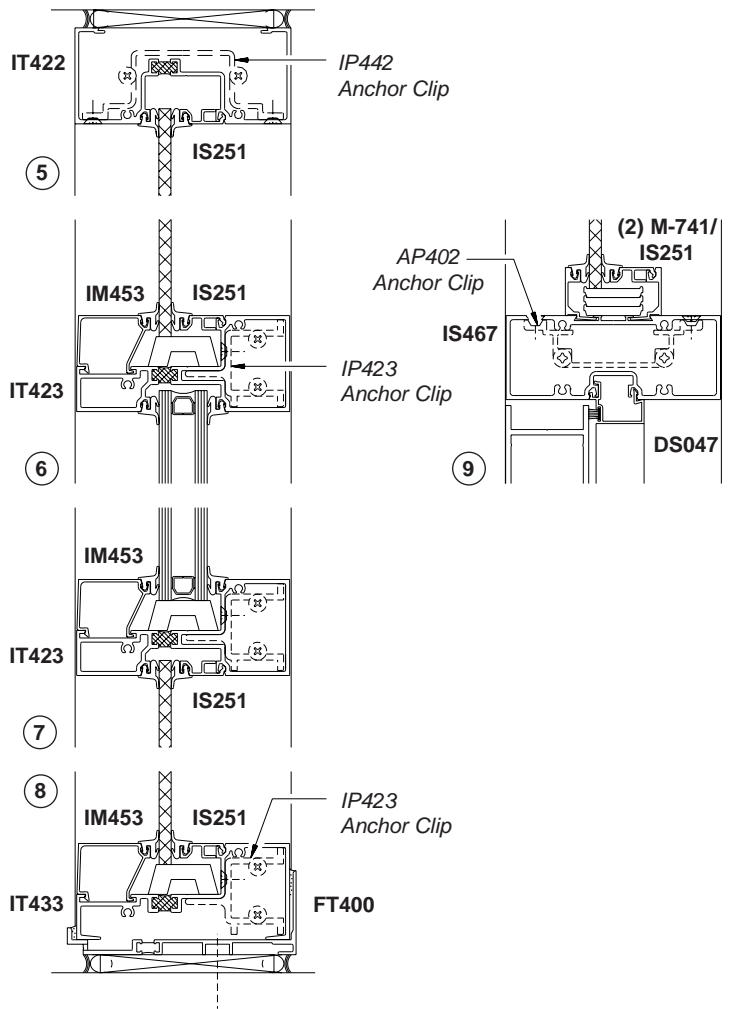
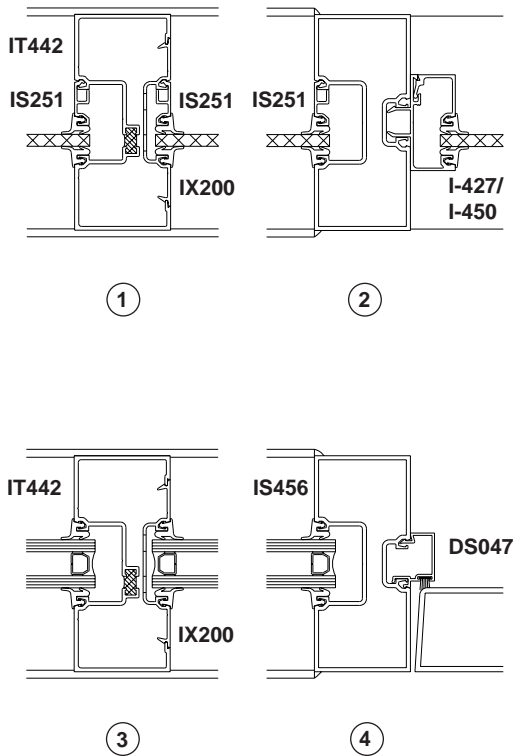

STOREFRONTS



Windload Charts

Center Glazed ♦ Series IT451

Mullions designed for 1/175 deflection ratio and for the following allowable working stresses:

Aluminum alloy 6063-T5: allowable stress for windload 12,929 psi. (89 MPa)
 Steel reinforcing allowable stress for windload 26,666 psi. (183 MPa)

Curves represent the limit values and are based on criteria for simple beam, uniformly loaded, using the distribution of wind forces on the wall with rectangular loading. Glass is not considered as contributing to resistance of deflection.

Limitation of vertical mullions for:
 CURVES A = 15 PSF (718 Pa)
 CURVES B = 20 PSF (957 Pa)
 CURVES C = 25 PSF (1197 Pa)
 CURVES D = 30 PSF (1436 Pa)



IT442/IX200
 $I = 2.936 (122.21 \times 10^4)$
 $S = 1.290 (21.14 \times 10^3)$



IT431/IX200
 $I = 4.927 (205.08 \times 10^4)$
 $S = 2.172 (35.59 \times 10^3)$

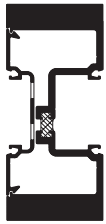

IT531/IX200
 $I = 9.397 (391.13 \times 10^4)$
 $S = 4.161 (68.19 \times 10^3)$



IT470/IT479
 $I = 4.274 (177.90 \times 10^4)$
 $S = 1.877 (30.76 \times 10^3)$

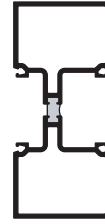

IT455
 $I = 2.924 (121.71 \times 10^4)$
 $S = 1.300 (31.30 \times 10^3)$

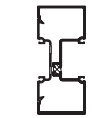
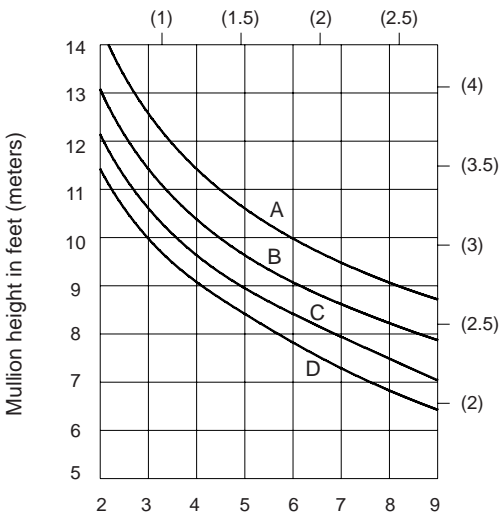

IT442/IX200

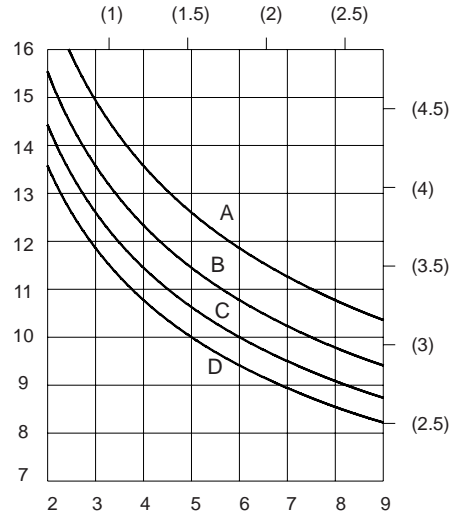

IT431/IX200

Mullion spacing in feet (meters)



STOREFRONTS

Windload Charts

Center Glazed ♦ Series IT451

Limitation of vertical mullions for:
 CURVES A = 15 PSF (718 Pa)
 CURVES B = 20 PSF (957 Pa)
 CURVES C = 25 PSF (1197 Pa)
 CURVES D = 30 PSF (1436 Pa)

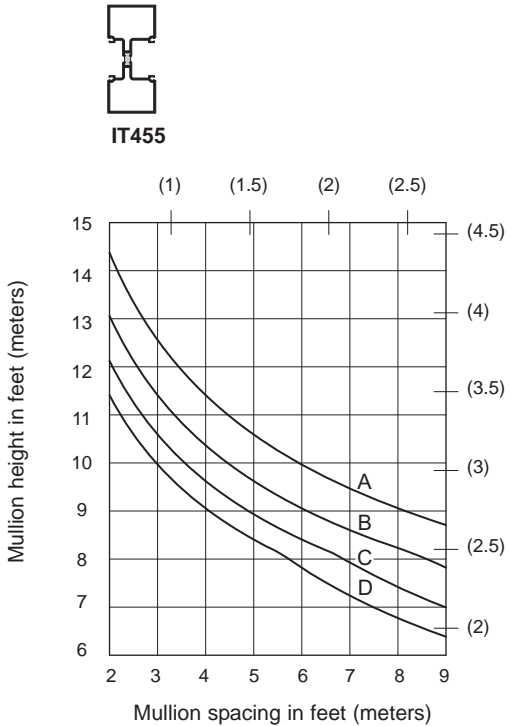
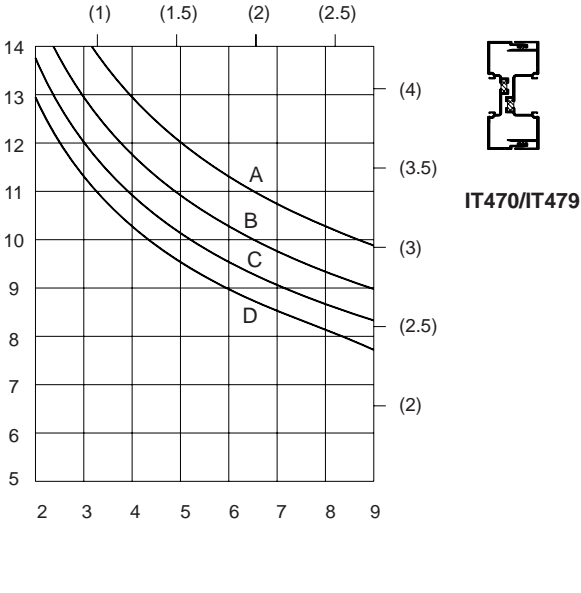
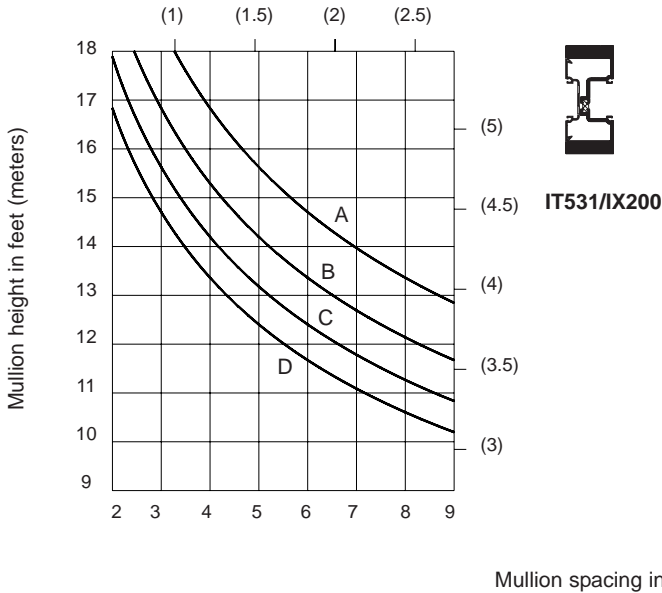

Deadload Chart

Deadload charts are based on 1/8" (3.2) maximum allowable deflection at the center point of the horizontal member and on a glass weight of 6.5 P.S.F. (31.74 Kg/m²)
 Glass shall rest on two setting blocks located at:
 CURVES A = 1/4 points
 CURVES B = 1/8 points or 8" (203.2) from corners, whichever is larger

